

LED BED BLOCK DIAGRAM

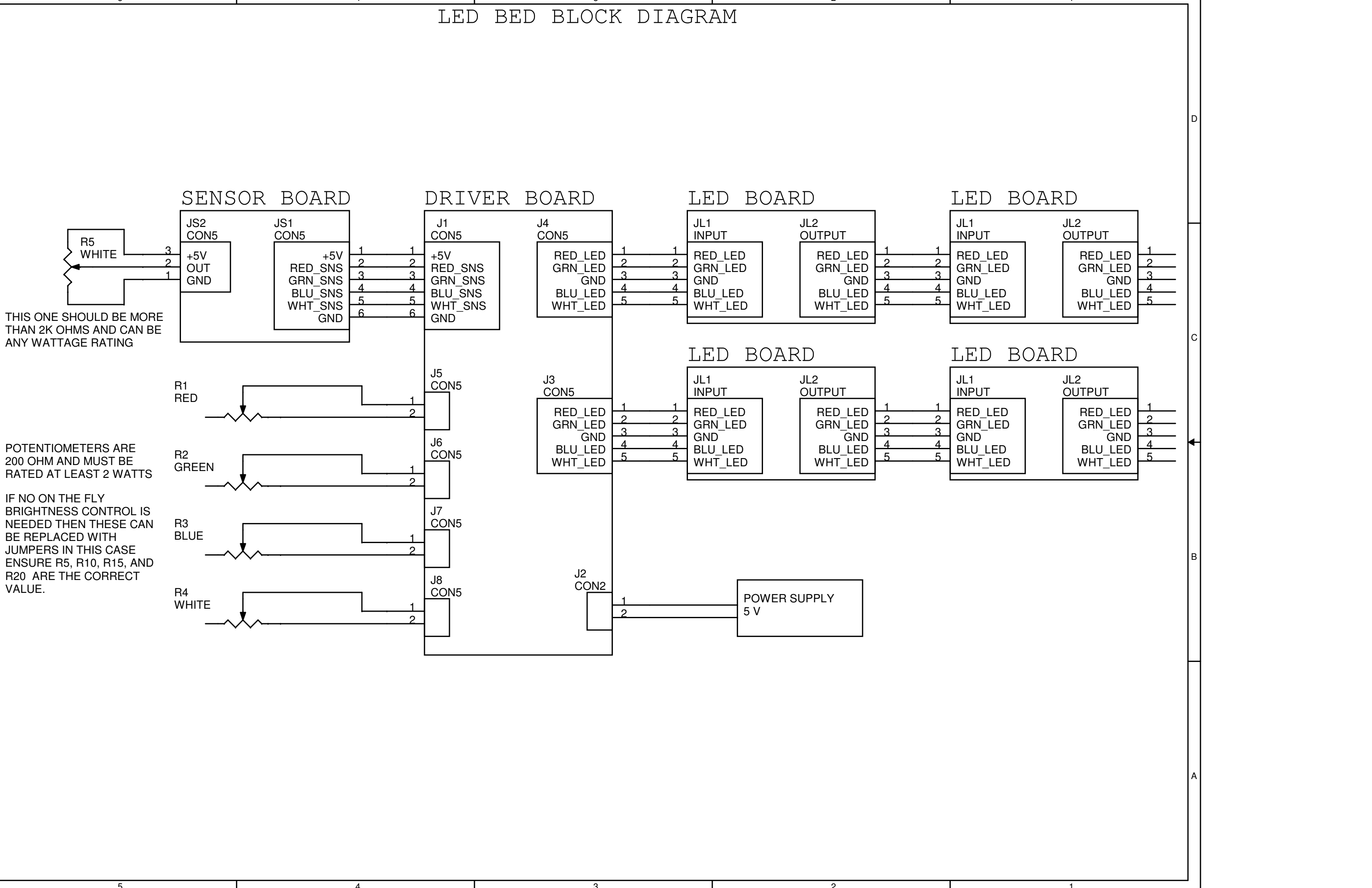

THIS ONE SHOULD BE MORE THAN 2K OHMS AND CAN BE ANY WATTAGE RATING

POTENTIOMETERS ARE 200 OHM AND MUST BE RATED AT LEAST 2 WATTS

IF NO ON THE FLY BRIGHTNESS CONTROL IS NEEDED THEN THESE CAN BE REPLACED WITH JUMPERS IN THIS CASE ENSURE R5, R10, R15, AND R20 ARE THE CORRECT VALUE.